

A background image of a sunset over a beach. The sun is low on the horizon, casting a warm orange glow across the sky and reflecting on the wet sand. Waves are breaking gently on the shore. A large, semi-transparent arrow shape points from the left towards the right, overlaid on the image.

Codecs comparison from TCO and compression efficiency perspective

Thierry Fautier
VP Video Strategy
Harmonic

Context

Process

Subjective results

Objective

Configuration

Complexity

Acronyms

Objective results

Comparison

Landscape

Savings

Conclusion

A crisis, the causes and a solution

Why this post?

Because there are rumours spreading about a presumed “MPEG-Video collapse” and Brownian motion-like initiatives trying to remedy – in some cases by the very people who have contributed to creating the “crisis”.

Who is the author of this post?

Leonardo Chiariglione, the founder and chairman of MPEG, but I am writing in a personal capacity.

Why is MPEG important?

In its 30 years of operation MPEG has created digital media standards that have enabled the birth and continue promoting the growth of digital media products, services and applications. Here are a few, out of close to 180 standards: MP3 for digital music (1992), MPEG-2 for digital television (1994), MPEG-4 Visual for video on internet (1998), MP4 file format for mobile handsets (2001), AVC for reduced bitrate video (2003), DASH for internet streaming (2013), MMT for IP broadcasting (2013) and more. In other words, MPEG standards have had and keep on having an impact on the lives of billions of people.

How could MPEG achieve this?

Thanks to its “business model” that can be simply described as: produce

“Leonardo’s blog”

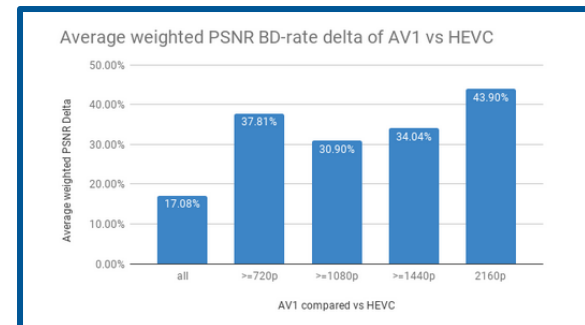
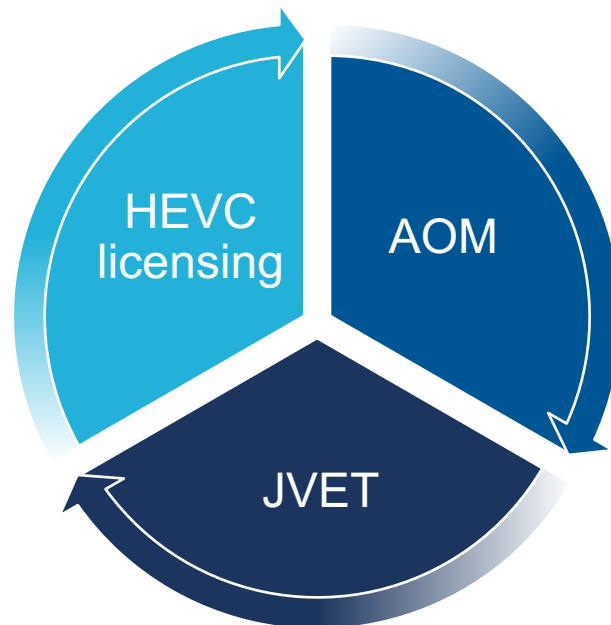

“Bitmovin blog”

The target of the new standard is to achieve a compression ratio leading to a bitrate reduction of at least 50% that of HEVC, including High Dynamic Range (HDR), in addition to providing native support to such emerging applications as 360° omni-directional video.

“VVC goal”



Provide a fair and objective performance comparison
of current and near future codecs

Codec

Also know as

Reference model



H.264

JM



H.265

HM

VVC

JVET

JEM

VP9



AV1

Codec Landscape

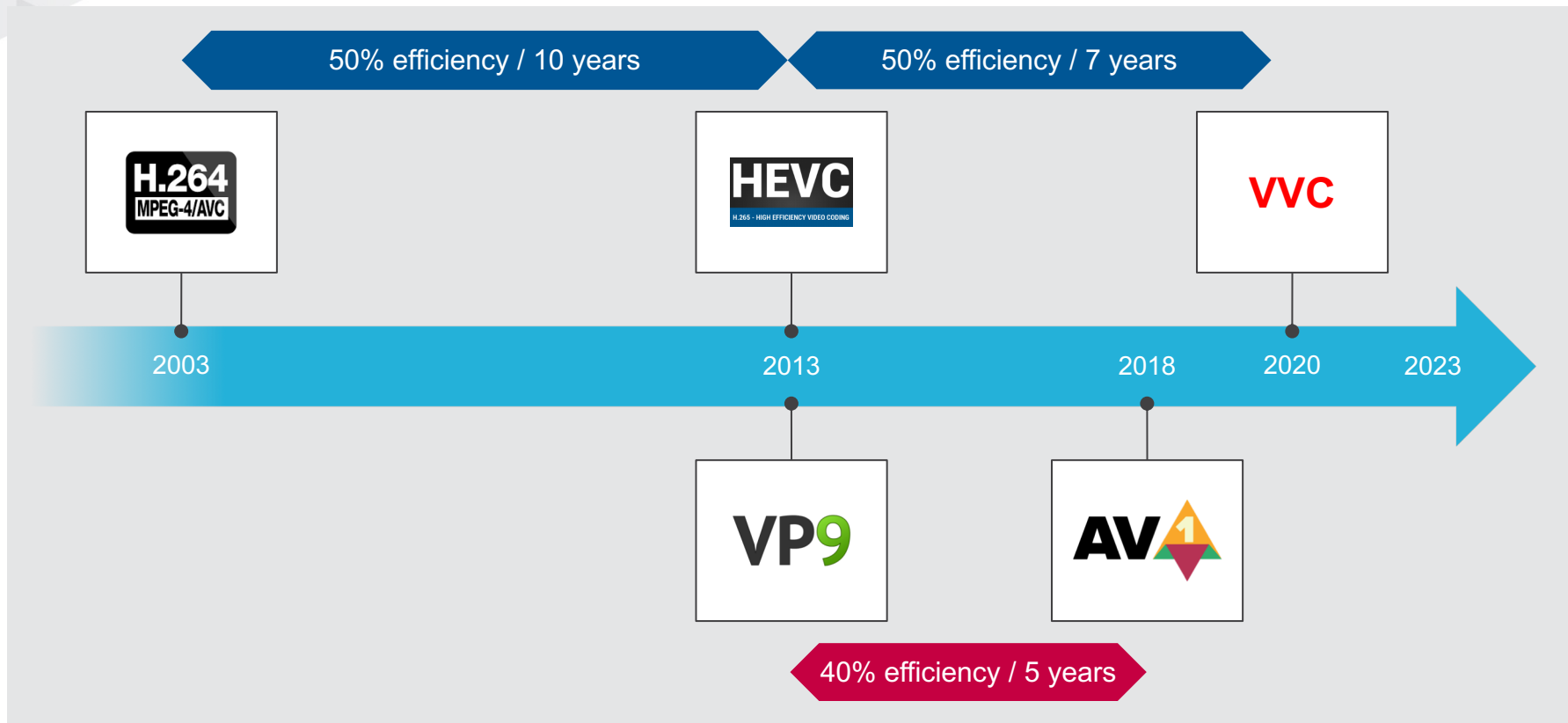

Encoding Process

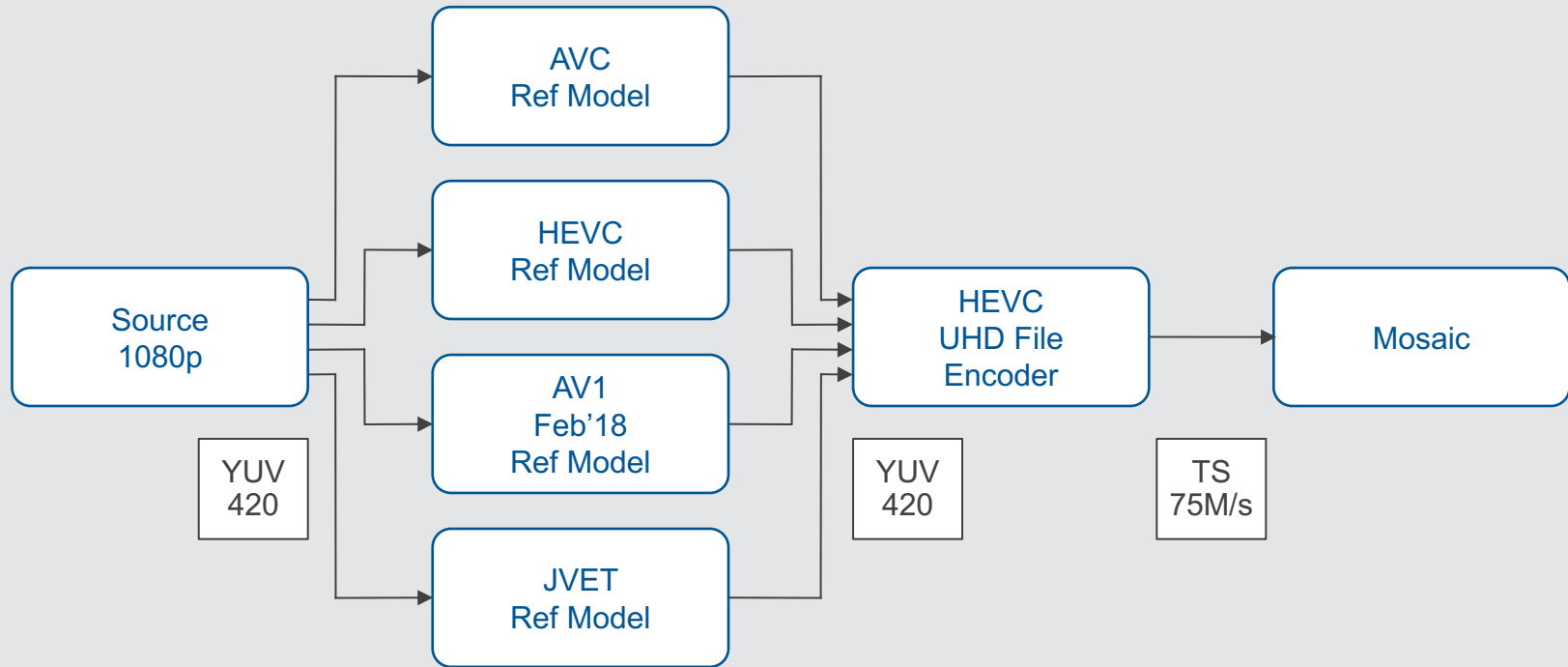

Codec common configuration

- Best for each
- 16 frame GOP size/ Golden frame interval
- 1 second Intra refresh period

AVC, HEVC and VVC

- Random Access with fixed QP value

AV1

- 2-pass VBR

NB: All details about command line options and reference model versions are available in upcoming IBC paper

6 HD sequences

- Cat&Robot
- Drums2
- FreeSardines
- CrowdRun
- ParkDancers
- ZurichAthletics

1-sec chunk based encoding

At several QP values/target bitrate

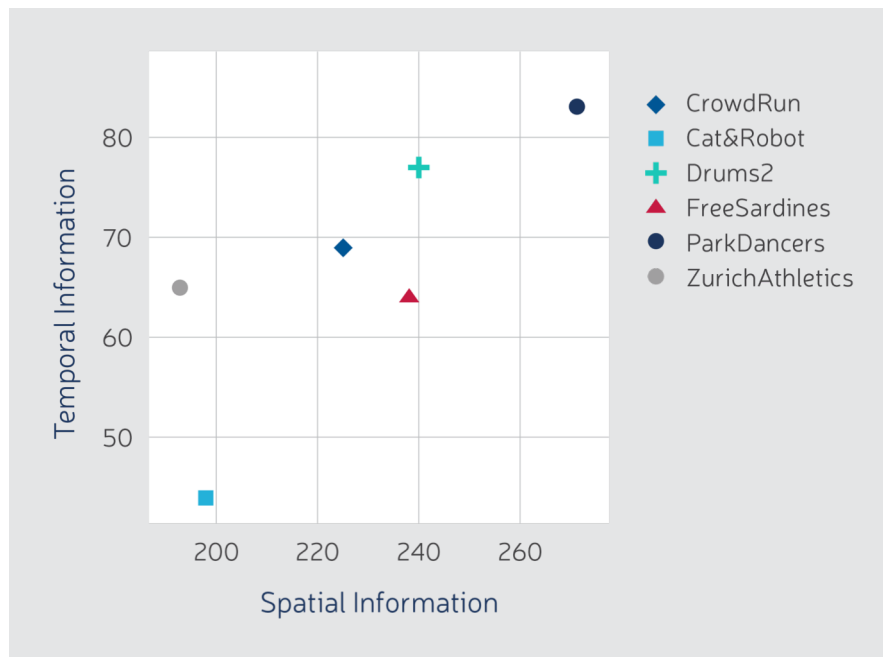

Objective Results Summary

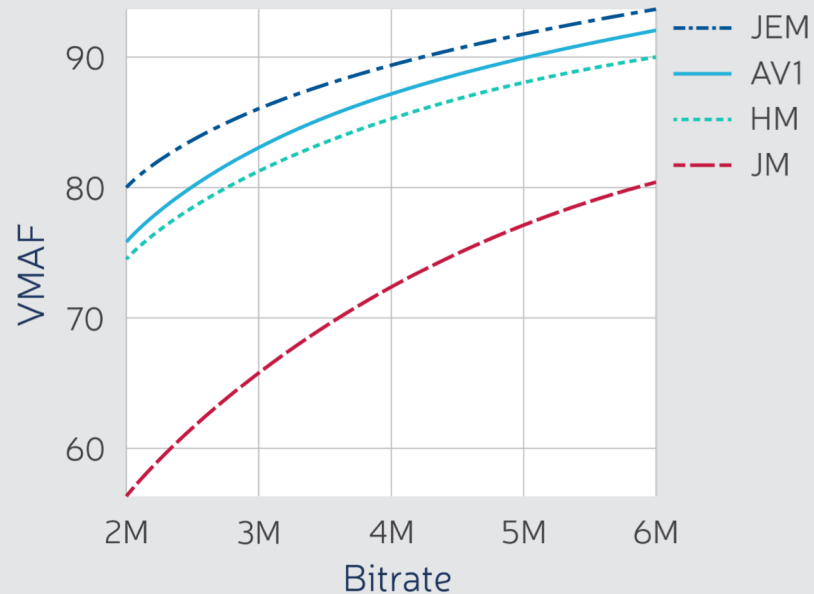
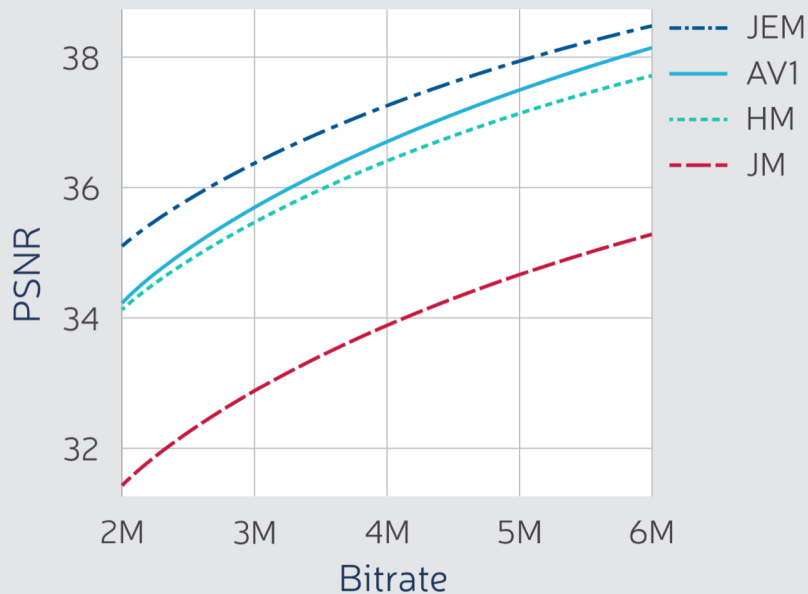

Objective Savings Summary

	PSNR (reference encoder in column)				VMAF (reference encoder in column)			
	JM	HM	AV1	JEM	JM	HM	AV1	JEM
JM		106%	131%	175%		103%	141%	200%
HM	-51%		8%	32%	-50%		17%	46%
AV1	-56%	-7%		25%	-58%	-14%		23%
JEM	-63%	-24%	-20%		-65%	-30%	-18%	

Note: This table represents the PSNR and VMAF BD rate delta values between codecs averaged over all the considered bitrates and sequences

Subjective Results Summary

	VVC	AV1	AVC
Expert viewing /HEVC	++	-	--

Note: Objective evaluation by Harmonic employees N=10

Codec Comparison : Complexity

Encoding/decoding time in x HEVC-HM

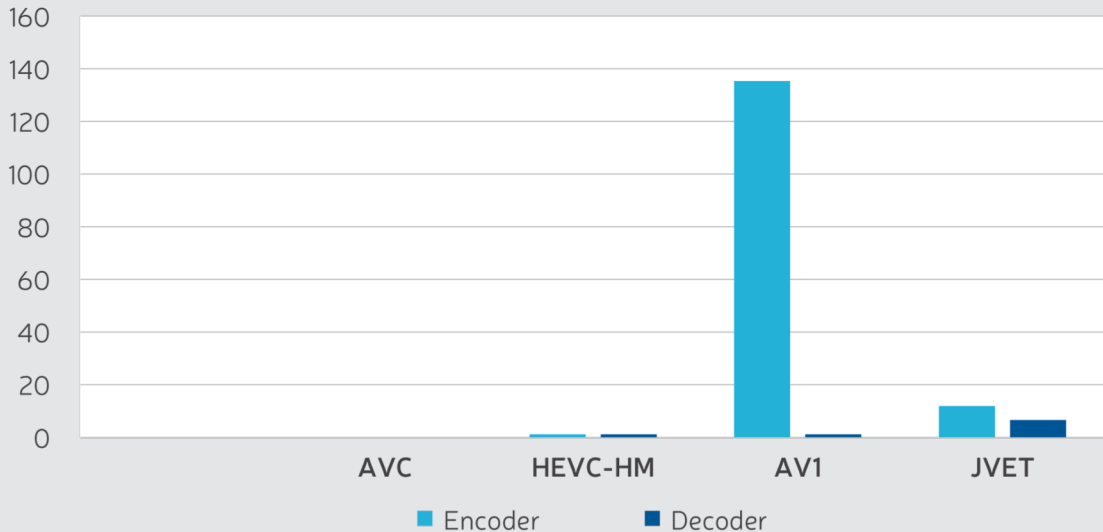

ENCODING

AV1 Ref Model > 100 x HEVC Ref Model, 1000x HEVC Real Time
Expect optimized AV1 to be ~100xHEVC



Objective Quality		Better
Subjective Quality	Better	
Saving vs HEVC		~10%
Encoder complexity vs HEVC		100x
Decoder complexity vs HEVC		~

Codec Applicability

H.265
High Efficiency Video Coding

AV1



Partial support

Full support*



Full support

2020+

STB

Full support

2020+

Connected TV

Full support

2020+

*based on AOM membership

Additional Criteria



VVC

	H.264 MPEG-4/AVC	H.265 High Efficiency Video Coding	AV1	VVC
Licensing	Easy	Complex	Royalty Free	Not Defined
Deployment	2006	2014	2020	2020+
Deployed Devices	>10Billion	>2Billion	NA	NA
Live Deployment Environment	Appliance SW Cloud	Appliance SW Cloud	Cloud	Cloud

Conclusion

AVC can not sustain comparison with more recent codecs, normal after 15 years

AV1 has similar compression performances vs HEVC, but encoder complexity kills the economics of live use case

AV1 is a good candidate for short tail lib (Amazon, Netflix, Hulu), for long tail lib (YouTube, Facebook) need to carefully look at encoding cost vs BW saving trade off

HEVC's advantage is performance and device support, big downside are licensing unknowns & cost

VVC is the most performing codec on the 2020+ timing, with still reservations on licensing (HEVC syndrom), now being addressed inside (AhG) and outside MPEG (MCIF)

Harmonic PURE compression able to support all codecs
Harmonic VOS ready to handle high complexity AV1 codec for Live

Thank you



@thierryfautier

Thierry.Fautier@harmonicinc.com